

# FICHE D'HOMOLOGATION / HOMOLOGATION FORM

034-IG-01



## COMMISSION INTERNATIONALE DE KARTING - FIA



### ALLUMAGE / IGNITION MiniXS

Constructeur / <i>Manufacturer</i>	SELETTRA SRL
Marque / <i>Make</i>	<b>SELETTRA</b>
Modèle / <i>Model</i>	<b>BF1885</b>
Catégorie / <i>Categorie</i>	Group 3
Durée de l'homologation / <i>Validity of the Homologation</i>	3 ans / 3 years
Nombre de pages / <i>Number of pages</i>	3
La présente Fiche d'Homologation reproduit descriptions, illustrations et dimensions de l'allumage au moment de l'homologation CIK-FIA.	<i>This Homologation Form reproduces descriptions, illustrations and dimensions of the ignition at the moment of the CIK-FIA homologation.</i>



Photo de l'ensemble rotor, stator, bobine, boîtier électronique et câblage complet /  
*Photo of the rotor, stator, coil, ECU unit and wiring loom*

Signature et tampon de l'ASN /  
*Signature and stamp of the ASN*

Signature et tampon de la CIK-FIA /  
*Signature and stamp of the CIK-FIA*

034-IG-01

**A** Dessin technique / *Technical drawing*

Dessin du vue de face et coupe du stator et rotor / *Drawing of the front and section view of stator and rotor*

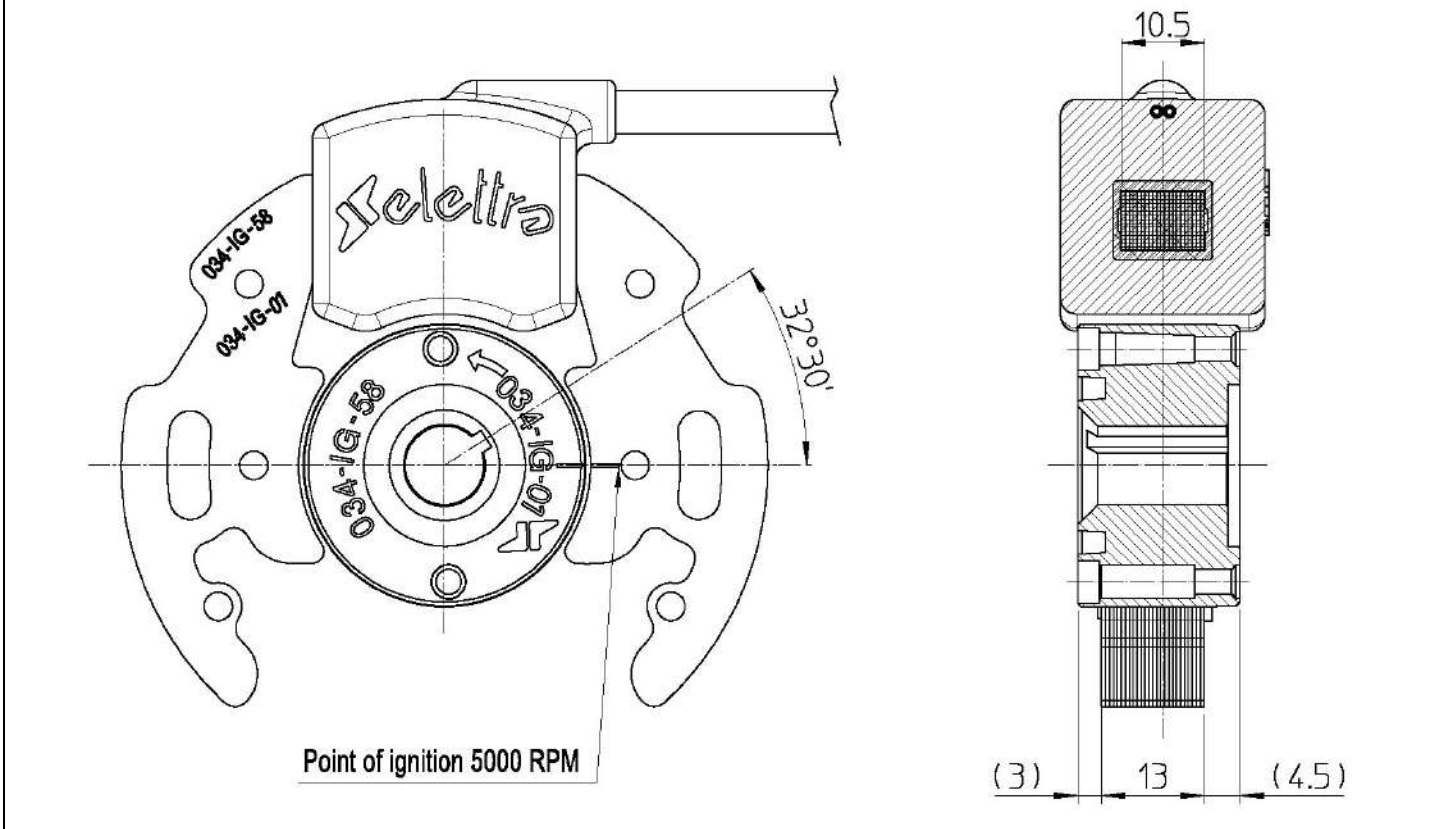

Dessin du vue de face et section de la bobine / *Drawing of front and section view of the coil*

Photo de la bobine / *Photo of the coil*

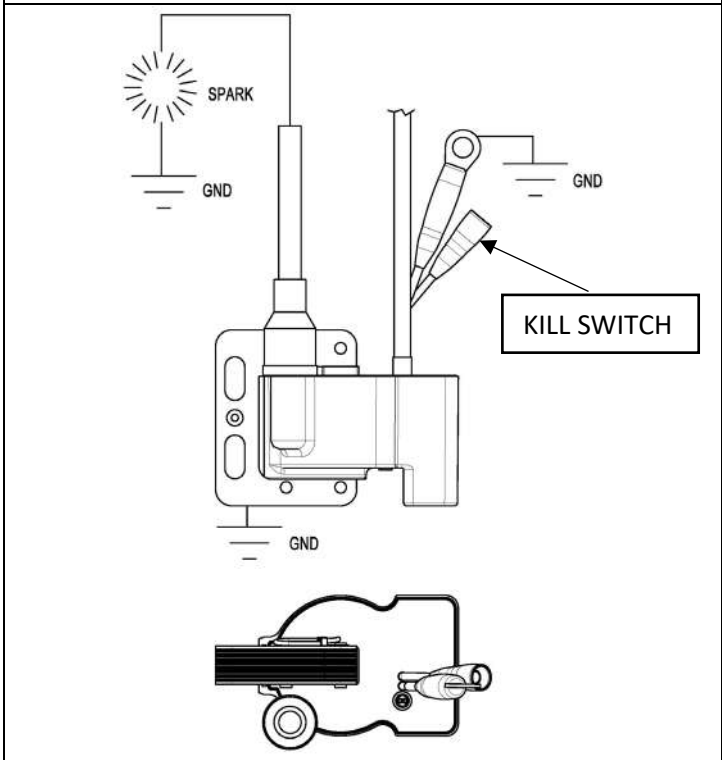

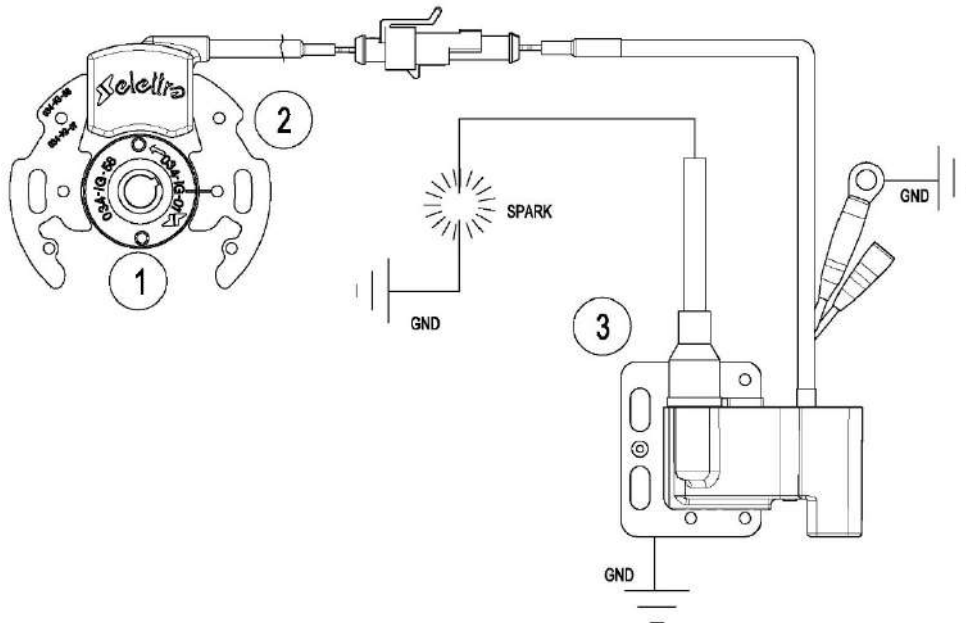
**B****Électrique / Electrical****Description du schéma électrique / Description of the electrical diagram****Liste des composants électroniques /  
List of electronic parts****Valeur de résistance des bobines /  
Resistance value of the coils**

1. Rotor

2. Stator

3. Ignition Coil/HT Coil

Bobine génératrice /  
Generator coil**80 Ohm ± 10%**  
**(25°C)**Haute tension secondaire  
/ Secondary high tension**2,6 kOhm ± 20%**  
**(25°C)****C****Graphique de la courbe d'avance / Graph diagram for advance**